



DV30L ELEVATOR DRIVE

OPEN LOOP CONTROL



SIZE



AC DRIVE MODEL → MODEL : DV30L S075E43
 INVERTER POWER → POWER: 7.5 KW
 RATED INPUT → INPUT: 3PH 380V ±20% 50/60HZ 28.5A
 RATED OUTPUT → OUTPUT : 3PH0-380V 0-500HZ 17A
 SERIAL NUMBER → S/N: 

KEYPAD

Labels for keypad components:
 STATUS BAR
 PROGRAM & EXIT KEY
 MULTI FUNCTION KEY
 RUN KEY
 UP KEY
 DSPLAY
 CONFIRM KEY
 SHIFT KEY
 STOP/RESET KEY
 DOWN KEY

MODEL	SIZE (MM)					
	A	B	H	H1	W	D
DV30L-4T-4.0	79	232	220	/	119	168
DV30L-4T-5.5	126	268	255	/	146	178
DV30L-4T-7.5	126	268	255	/	146	178
DV30L-4T-11	126	268	255	/	146	178

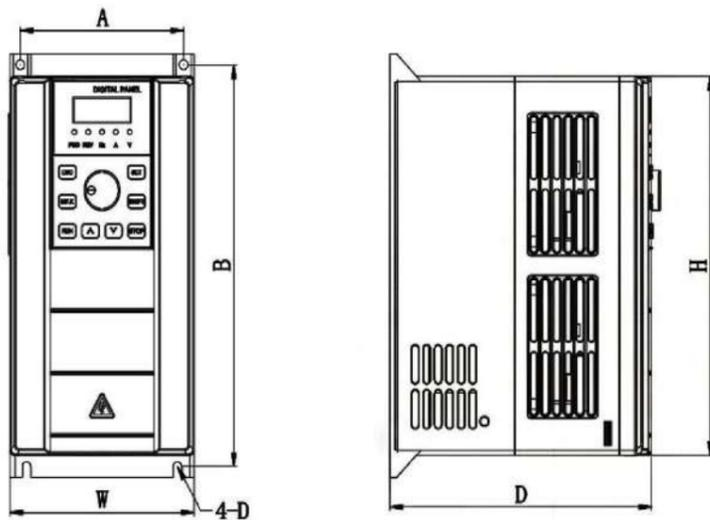

DISPLAY	CHARACTER	DISPLAY	CHARACTER	DISPLAY	CHARACTER
0	0	1	1	2	2
3	3	4	4	5	5,S
6	6	7	7	8	8
9	9	A	A	b	B
c	C	c	c	d	D
E	E	F	F	L	L
n	N	P	p	r	R
r	T	U	U	u	U

IN/OUT TERMINALS

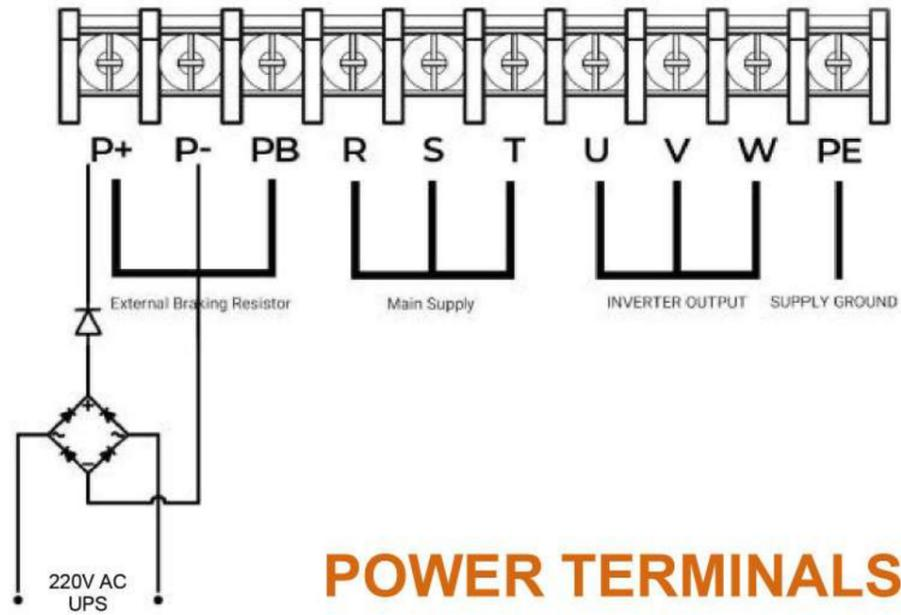

POWER TERMINALS

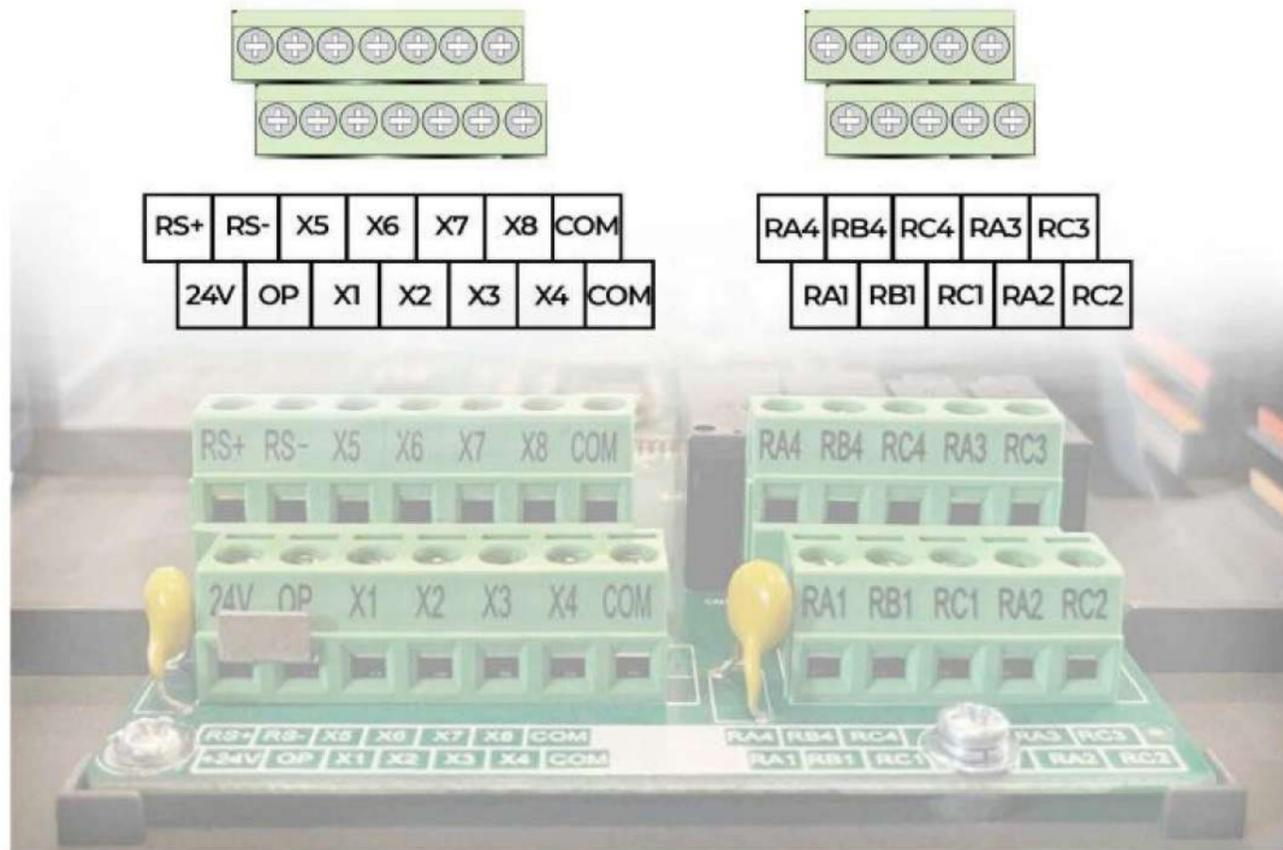

WIRING DIAGRAM

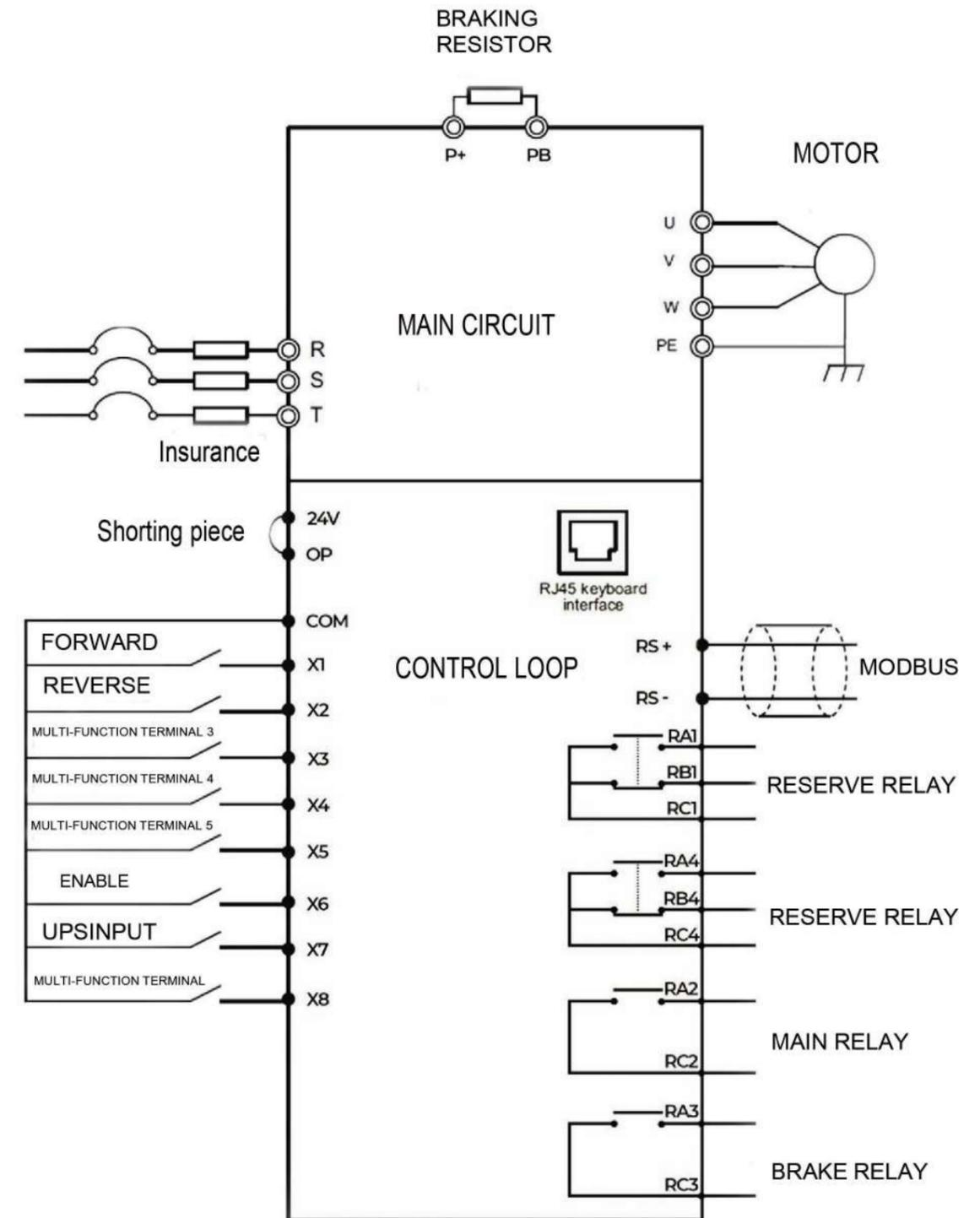

Event	Descriptions	Function	Drive Status
ta	-Drive healthy -MC and brake Contactor are energised	—	RUN
tb	-Drive Trip -IGBTs disable -Brake contactor de-energised	—	Trip
tc	-MC contactor got de-energised provided drive IGBTs are disabled after 0.1 sec		Trip
t1	-Drive waits to enable by lift controller	—	Inhibit
t2	-Drive MC contactor output energized when direction demand command enable by the lift controller. -Desired preset speed reference command enable by lift controller	P8-60	Ready
t3	-Drive IGBTs immediately go into active mode after the desire drive run permit delay ON set time has elapse.	P8-60	STOP
t4	-DC injection active -Motor brake contactor energized when motor current demand excess the brake release current level and brake release frequency	P6-05	RUN
t5	-Motor brake contactor is energized -Optimize profile generator active -Motor start to run	P6-06 P8-55 P8-56 P8-57 P6-03 P6-04	RUN
t6	-DC injection 1 disable after the desired set time has elapsed	P6-06	RUN
t7	-Start optimizer profile generator disable after the desired set time has elapse.	P6-04	RUN
t8	-Motor ramp up to the desire preset speed reference.	P6-08 P6-09 PO-17 PC-Ox	RUN
t9	-Drive output at speed status	PC-Ox	RUN
t10	-Change of preset speed reference demand -Motor ramp down to the desire preset speed reference	P6-08 P6-09 PO-17 PC-Ox	RUN
t11	-Drive output at speed status	PC-Ox	RUN
t12	-Direction demand command disabled -Motor ramp down to zero speed	P6-08 P6-09	P6-3 P8-56 P8-59
t13	-DC injection active when drive output falls below the DC injection 2 frequency threshold	PO-18	
t14	-Brake contactor got de-energise when the drive output frequency fall below the brake apply frequency	P6-11	
t15	-DC injection still active when brake contactor got de-energise.	P6-13	RUN
t16	-DC injection disable after the desire set time has elapse	P6-14	STOP
t17	-Drive IGBTs got disable -MC contactor delay OFF time active	■...	Ready
t18	-MC contactor de-energise after the desire set time has elapse	P8-61	Inhibit

4.2 Elevator performance fine tuning

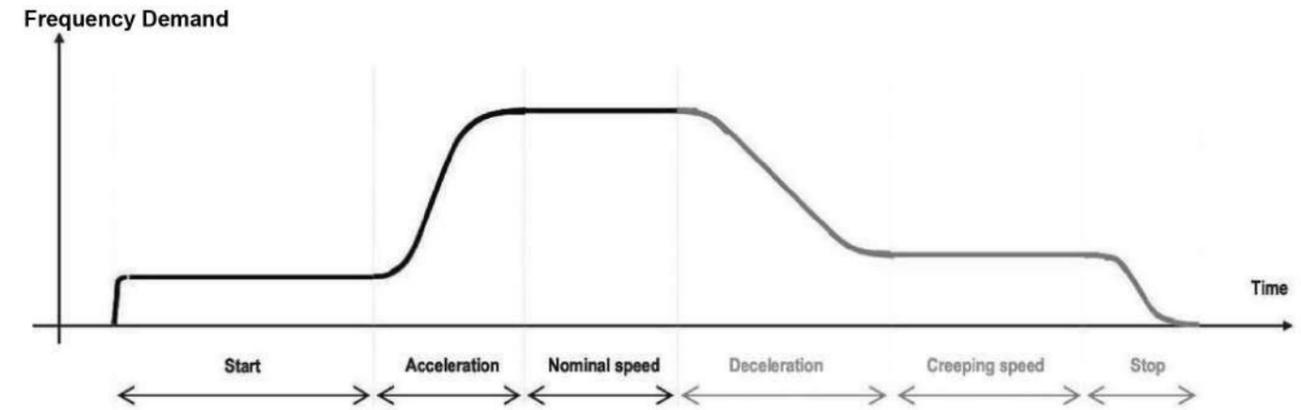

Stage	Symptom	Diagnostics	Remedies
Start	Rollback	Brake device releases too early	Increase P8-57, ranging 0 to 0.5s
		Start frequency is too low	Increase P6-03, ranging 0 to 1.5Hz
		Torque output is insufficient	Make sure P3-00=0, P3-01=0
Start	Starting jerk	Brake device releases too late	Decrease P8-57, ranging 0 to 0.5s
		Start frequency is too high	Decrease P6-03, ranging 0 to 1.5Hz
Acceleration	Jerk when acceleration starts	Too fast acceleration at this section	Increase P6-08, ranging 0 to 80%; Or increase PO-17, ranging 0 to 20s
	Jerk when acceleration end	Too fast acceleration at this section	Increase P6-09, ranging 0 to (95-(P6-08))% Or increase PO-17, ranging 0 to 20s
	Overshoot when acceleration ends	Too big speed loop PI gains	Decrease P2-03, ranging 0 to 100 Or increase P2-04, ranging 0 to 10
	Vibration	Too small margin between P2-02 and P2-05	Make sure P2-05 - P2-02 > 3H Δ , usually increase P2-05, ranging from P2-02 to 7Hz
		Overcurrent stall prevention occurs	Make sure P3-18=170%
Nominal speed	Vibration	Too big speed loop PI gains	Decrease P2-00 or P2-03, ranging 0 to 100; Or increase P2-01 or P2-04, ranging 0.01 to 10.00
		Too big current loop PI gains	Double check the motor parameters and then perform motor auto-tuning once more

Frequency Demand

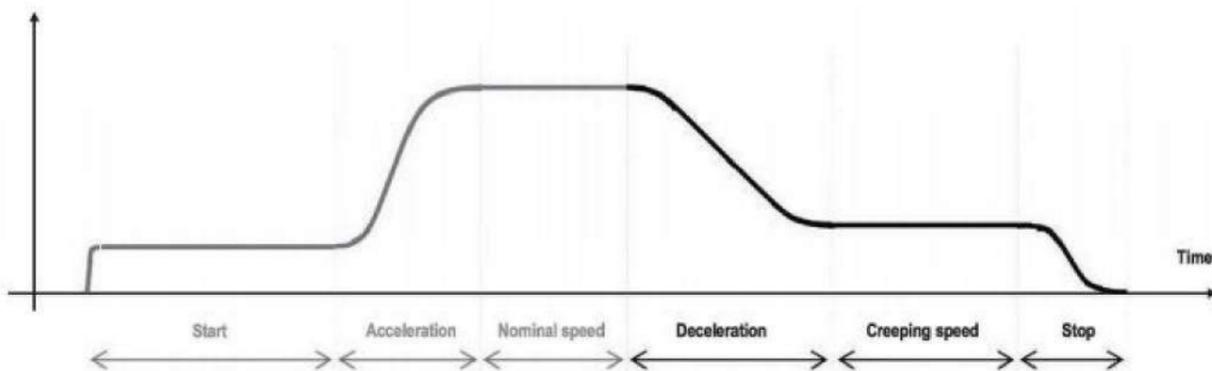

Stage	Symptom	Diagnostics	Remedies
Deceleration	Jerk when deceleration starts	Too fast deceleration at this section	Increase P6-26, ranging 0 to 80%; Or increase PO-18, ranging 0 to 20s
	Vibration	Overcurrent stall prevention occurs	Make sure P3-18=170%
Deceleration	Jerk when deceleration ends	Too fast deceleration at this section	Increase P6-27, ranging 0 to 80%; Or increase PO-18, ranging 0 to 20s
	Vibration	Torque output is insufficient	Make sure P3-00=0, P3-01=0
Creeping speed	Elevator gets stuck	Torque output is insufficient	Make sure P3-00=0, P3-01=0
	Move much slower than expected	Torque output is insufficient Too small creeping speed setting	Make sure P3-00=0, P3-01=0 Increase P4-16, ranging 0 to 100%; Or decrease relevant multi-reference
Stop	Jerk	Too fast deceleration at this section	1. Increase P6-27, ranging 0 to 80%; Or increase PO-18, ranging 0 to 20s; 2. Use second deceleration time P8-04: First, set P8-04 bigger than P0-18, ranging P0-18 to 20s; then set P8-26 = creeping speed
		Braking device applies too early	Make sure P8-58=0.5Hz, then increase P8-59, ranging 0 to 0.5s
		Too strong DC injection at stop	Decrease P6-13, ranging 0 to 100%
	Slip	Too short DC injection active time at stop	Increase P6-14, ranging 0 to 1s
		Too weak DC injection at stop	Increase P6-13, ranging 0 to 100%
	Inaccurate levelling position	Braking device applies too late	Make sure P8-58=0.5Hz, then decrease P8-59, ranging 0 to 0.5s
Too slow deceleration		1. If P8-04 is not applied, then decrease P0-18, ranging 0 to 20s; 2. If P8-04 is applied, then firstly decrease P8-04, ranging P0-18 to 20s; secondly set P8-26 = creeping speed	
Slip occurs		Refer to problem „Slip“	
Levelling varies with different loads	Too weak slip compensation	For SVC, increase P2-06 or F 2-00; For VF, increase P3-09	

4.3 Setup flowchart

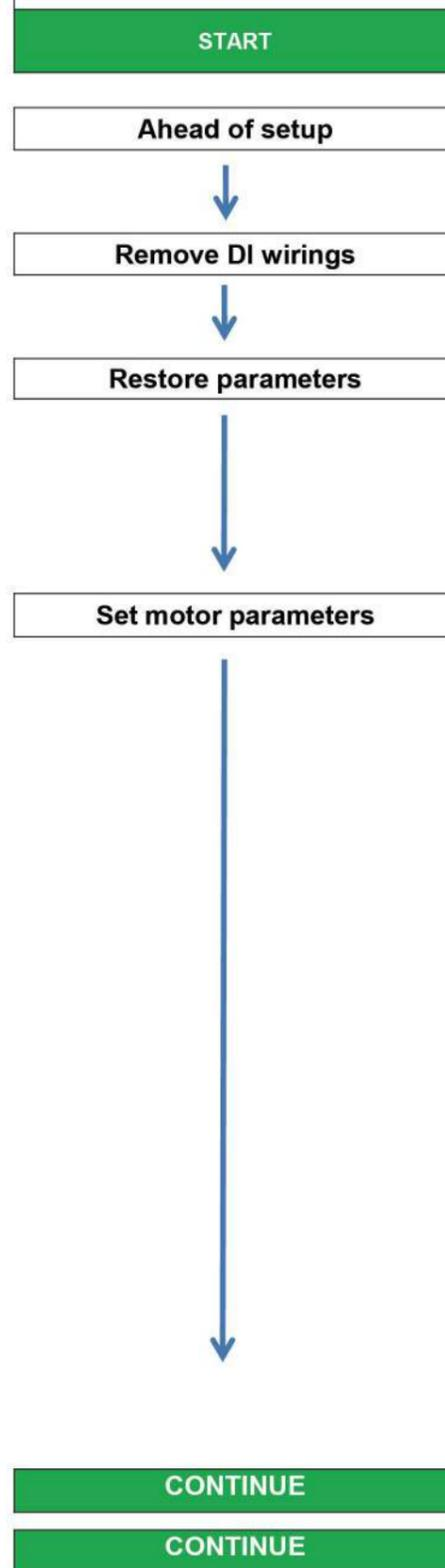

Para	Parameter name	Default	Commissioning
	Default values are elicited from enormous real elevator applications, so users can rely on them usually, only some adjustments are necessary. If parameter restoration is prohibited due to some reasons, then the following steps have to be followed one by one.		
	usually if any DI is set as Forward or Reverse run and if signal is active, then some operations cannot succeed, such as restoring parameters, changing command source, which are necessary steps for quick setup. So it's seriously recommended to remove DI wirings at the beginning of commissioning.		
PP-01	Parameter operation	0	1
	0: No operation 1: Restore default settings except motor parameters 2: Clear records including errors 4: Restore user's backup parameters 501: Backup parameters		
	Motor Nameplate		
P1-01	Rated motor power	model dependent	
	Unit: kW		
P1-02	Rated motor voltage	400	
	Unit: V		
P1-03	Rated motor current	model dependent	
	Unit: A		
P1-04	Rated motor frequency	50.00	
	Unit: Hz		
P1-05	Rated motor speed	1440	
	Unit: rpm.		
Para.	Parameter name	Default	Commissioning
Para.	Parameter name	Default	Commissioning

Select command source



Perform motor auto tuning



Select Control mode



Select frequency reference source



CONTINUE

CONTINUE

P0-02	Command source selection	1	0
0: Operation panel control (indicator „LOCAL/REMOT OFF) 1: Terminal control (indicator „LOCAL/REMOT ON) 2: Communication control (indicator „LOCAL/REMOT blinking)			
P1-37	Auto-tuning selection	0	3
0: No auto-tuning 2: Asynchronous motor dynamic auto-tuning 3: Asynchronous motor static auto-tuning(NEW) NOTE: Motor won't rotate at this stage. Slens of auto-tuning 1. Make sure the UVW connection between AC drive and motor is not cut oFF by output contactor; if it is cut oFF, then manually handle with the output contactor; 3. Set P1-37=3, press ENTER , then LED on panel will display letters TUNE' 4. Press the key RUN on panel, then motor starts auto-tuning, it usually takes about 30 seconds to finish this auto-tuning, wait until LED stops displaying JUNE' 5.Restore P0-02 to the default value 1.			
P0-01	Control mode selection	2	0or2
0: SVC control 2: VF control			
P0-03	Main frequency source X selection	6	2or6
0:Digital setting P0-08(pressing \circ or Can change P0-08 easily, and the changed value won't be cleared even after power oFF) 1:Digital setting P0-08(pressing or Can change P0-08 easily, but changed value would be cleared after power oFF) 2: AI1 3: AI2 4: AI3 5: Pulse setting (DI5) 6: Multi-reference setting 7: Simple PLC 8: PID 9: Communication setting			
P4-13	AI curve 1 minimum input	0.00	0.00
0VtoP4-15;			
P4-14	Corresponding setting of AH minimum input	0.0	0.0
-100.0% to 100.0%			
P4-15	AI1 maximum input	5.00	
P4-13 to 10.00 V			
P4-16	Corresponding setting of AH maximum input	100.0	
-100.0% to 100.0%			
Para.	Parameter name	Default	Commissioning
Para.	Parameter name	Default	Commissioning

Set multi-reference values

if multi-reference is frequency reference



Set DI function



CONTINUE

CONTINUE

PC-01	Reference 1	100.0	100.00
0.0 to 100.0%. Note: PC-01 is set as nominal speed of elevator.			
PC-02	Reference 1	11.0	11.0
0.0 to 100.0%. Note: PC-02 is set as creep speed of elevator.			
PC-04	Reference 4	40.0	40.00
0.0 to 100.0%. Note: PC-04 is set as inspection speed of elevator.			
PC-08	Reference 8	20.0	20.0
0.0 to 100.0%. Note: PC-08 is set as ARD speed of elevator.			
P4-00	DI1 function selection	1	1 (Forward run)
0: No function 1: Forward RUN (FWD) 2: Reverse RUN (REV) 8: IGBT Enable 9: Fault reset (RESET) 12: Multi-reference terminal 1 13: Multi-reference terminal 2 14: Multi-reference terminal 3 Setting range:0 to 59; Note: this signal comes from elevator controller.			
P4-01	DI2 function selection	2	2 (Reverse run)
Setting range same as DI1; Note: this signal comes from elevator controller.			
P4-02	DI3 function selection	12	12
Setting range same as DI1 Note: if analog input is used as frequency reference, then DI3 is useless, just leave it alone. If multireference is used as frequency reference, then signal .nominal speed' comes from elevator controller.			
P4-03	DI4 function selection	13	13
Setting range same as DI1. Note: if analog input is used as frequency reference, then DI4 is useless, just leave it alone. If multireference is used as frequency reference, then signal .creep speed' comes from elevator controller.			
P4-04	DI5 function selection	14	14
setting range same as DI1; Note: if analog input is used as frequency reference, then DI5 is useless, just leave it alone. If multireference is used as frequency reference, then signal .inspection speed' comes from elevator controller.			
P4-05	DI6 function selection	0	
setting range same as DI1;			
Para.	Parameter name	Default	Commissioning
Para.	Parameter name	Default	Commissioning

Set Do function	P5-01	FM function selection		
		0 : No output 1 : AC drive running 2 : Fault output 36: Software current exceeding limit 42 : Brake output 43 : MC (Magnetic contactor) output Setting range:0 to 59; Note: this signal goes to magnetic contactor.		
	P5-02	Relay function selection(TA/TB/TC)	43	43 (MC)
		Setting range same as FM; Note: this signal goes to magnetic controller.		
	P5-03	Relay function selection(PA/PB/PC)	42	42(Brake)
		Setting range same as FM; Note: this signal goes to brake contactor.		
Set magnetic contactor	P8-60	Drive run delay ON set time	0.20	0.20
		0.00 to 10.00 Sec; Note: if MC is controlled by elevator controller, then P8-60 is useless.		
	P8-61	MC contactor delay OFF set time	0.20	0.20
		0.00 to 10.00 Sec; Note: if MC is controlled by elevator controller, then P8-61 is useless.		
Set brake contactor	P8-55	Brake release current threshold	5	5
		0 to 200%;		
	P8-56	Brake release frequency threshold	0.00	0.0
		0.00 to 25.00 Hz;		
	P8-57	Brake release delay ON set time	0.0	0.0
		0.0 to 5.0 Sec;		
	P8-58	Brake apply frequency threshold	0.5	0.5
		0.00 to 25.00 Hz;		
	P8-59	Brake apply delay OFF set time	0.2	0.2
		0.0 to 5.0 Sec;		
Set acceleration and deceleration	PO-17	Acceleration time 1	3.0	3.0
		0.0 to 6500.0 sec.		
	PO-18	Deceleration time 1	2.0	2.0
		0.0 to 6500.0 sec.		
Set startup frequency	P6-03	Startup frequency	1.0	1.0
		0.0 to 10.0 Hz;		
	P6-04	Startup frequency active set time	0.3	0.3
		0.0 to 100.0 Sec		
CONTINUE	Para.	Parameter name	Default	Commissioning
CONTINUE	Para.	Parameter name	Default	Commissioning

Set DC injection for stopping	P6-07	Acceleration/Deceleration mode	3	3
		0: Linear acceleration/ deceleration 3: S-curve acceleration/ deceleration C		
	P6-08	Time proportion of S-curve at Accel start	80.0	80.0
		0.0% to Min[(100.0% - P6-09), 80%]		
	P6-09	Time proportion of S-curve at Accel end	10.0	10.0
		0.0% to Min[(100.0% - P6-08), 80%]		
	P6-26	Time proportion of S-curve at Decel start	20.0	20.0
		0.0% to Min[(100.0%-P6-27),80%]		
	P6-27	Time proportion of S-curve at Decel end	30.0	30.0
		0.0% to Min[(100.0% - P6-26), 80%]		
	P6-11	DC injection 2 frequency threshold	0.50	0.50
		0.00 Hz to maximum frequency		
	P6-12	DC Injection 2 delay ON set time	0.0	0.0
		0.0 to 36.0 Sec		
	P6-13	DC injection 2 level	30	30
		0 to 100 Hz		
	P6-14	DC injection 2 active set time	0.5	0.5
		0.0 to 36.0 Sec		
	P3-00	V/F curve selection	0	0
		0: Linear V/F 1: Multi-point V/F SETTING RANGE:		
	P3-01	Torque boost	0.0	0.0
		0.0 to 30.0 %; Note: if it is 0, then auto torque boost is activated, and it is recommended to use auto torque boost		
	P2-00	Speed loop proportional gain 1	10	10
		0 to 100.		
	P2-01	Speed loop integral time 1	0.5	0.5
		0.01 to 10.00 Sec.		
	P2-02	Switchover frequency 1	3.00	3.00
		0.00 to P2-05		
	P2-03	Speed loop proportional gain 2	30	30
		0 to 100.		
	P2-04	Speed loop integral time 2	0.5	0.5
		0.01 to 10.00 Sec.		
	P2-05	Switchover frequency 2	7.00	7.00
		P2-02 to maximum output frequency		
OVER				

This function can work by assigning "IGBT Enable" function to a digital input, please refer to the table below to set. Take DI6 for example: assign "IGBT Enable" to DI6, then set P4-05=8. If it's necessary to change active mode of IGBT Enable, then use P4-38 or P4-39 to set (low level or high level active).

4.4 IGBT Enable

In all elevator applications, an Output Contactor is installed between the AC drive output U, V, W and the motor. In an emergency, the Safety Line is opened due to an unsafe condition and the Output Contactor disconnects the power from the inverter to the motor (the motor brake is also applied at the same time). When the Output Contactor opens with current flowing through to the motor (inverter IGBTs are active), there will be arcing in the Output Contactor depending on the motor inductive energy. Arcing of the Output Contactor can reduce the lifetime of the contactor and in some severe cases can damage the contacts poles. Therefore it is recommended to electronically switch off the AC drive IGBT firing circuits before opening the Output Contactor (milliseconds later). The AC drive IGBT firing can be electronically switched off with the

CAUTION "IGBT Enable" function as shown in the timing charts below.

An Output Contactor **MUST** always be installed as the final safety power cut off to the motor. The "IGBT Enable" function is NOT a substitute for an Output Contactor, it is designed to work together with the Output Contactor.

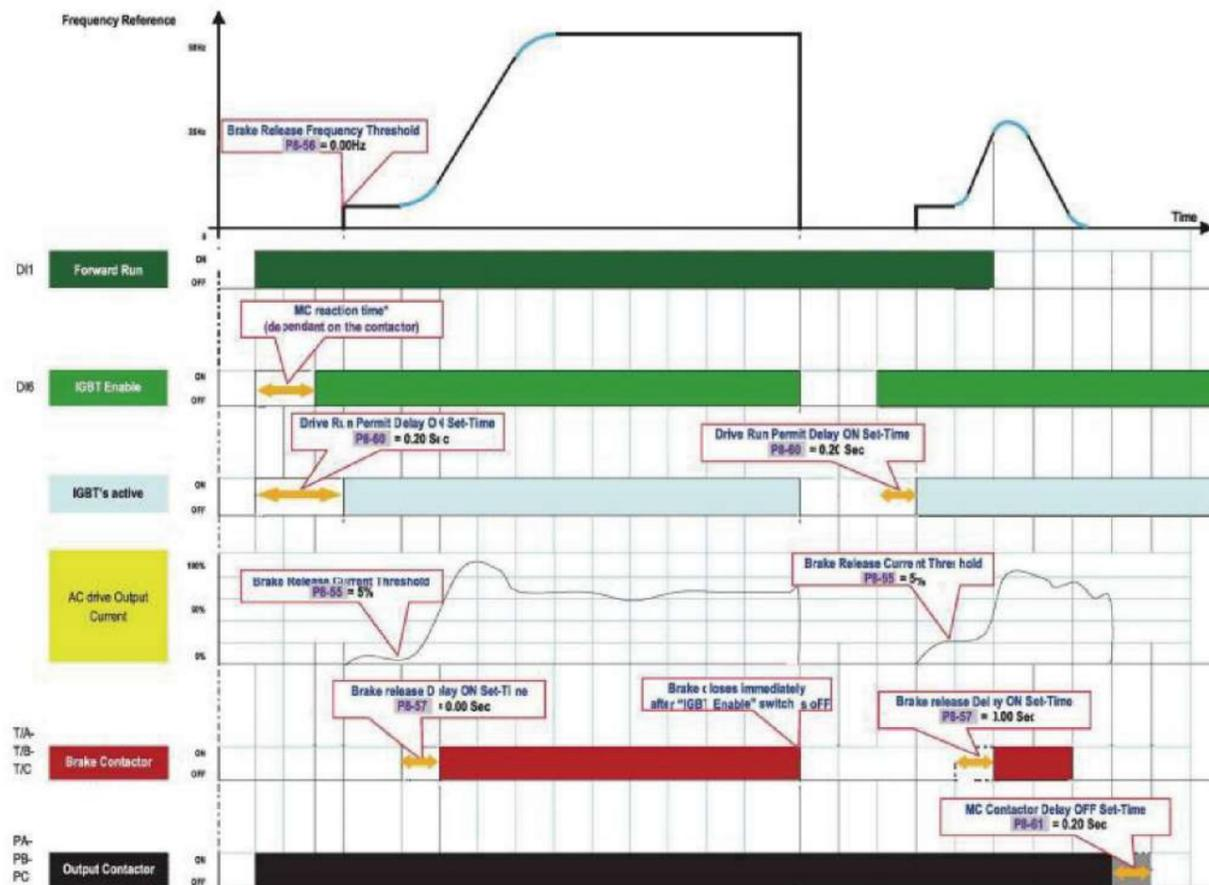

* **MC reaction time:** the reaction time of output relay of MC.

For some applications, the status of output contactor needs to be checked before AC drive starts up, hence one relay output of MC will feedback to IGBT Enable (above in the diagram it is DI6).

Function Code	Parameter Name	Setting Range	Unit	Default	Commission
P4-00	D11 function selection	0: No function	N.A	1	
P4-01	DI 2 function selection	1: Forward RUN (FWD)	N.A	2	
P4-02	DI 3 function selection	2: Reverse RUN (REV)	N.A	12	
P4-03	DI 4 function selection		N.A	13	
P4-04	DI 5 function selection	Q: IUD tnaoie	N.A	14	
P4-05	DI 6 function selection	12: Multi-reference terminal 1	N.A	0	8
P4-06	DI 7 function selection	13: Multi-reference terminal 2	N.A	15	
				0	
P4-07	DI 8 function selection	14: Multi-reference terminal 3	N.A	0	
P4-08	DI 9 function selection	15: Multi-reference terminal 4	N.A	0	
				0	
P4-09	D110 function selection		N.A	0	

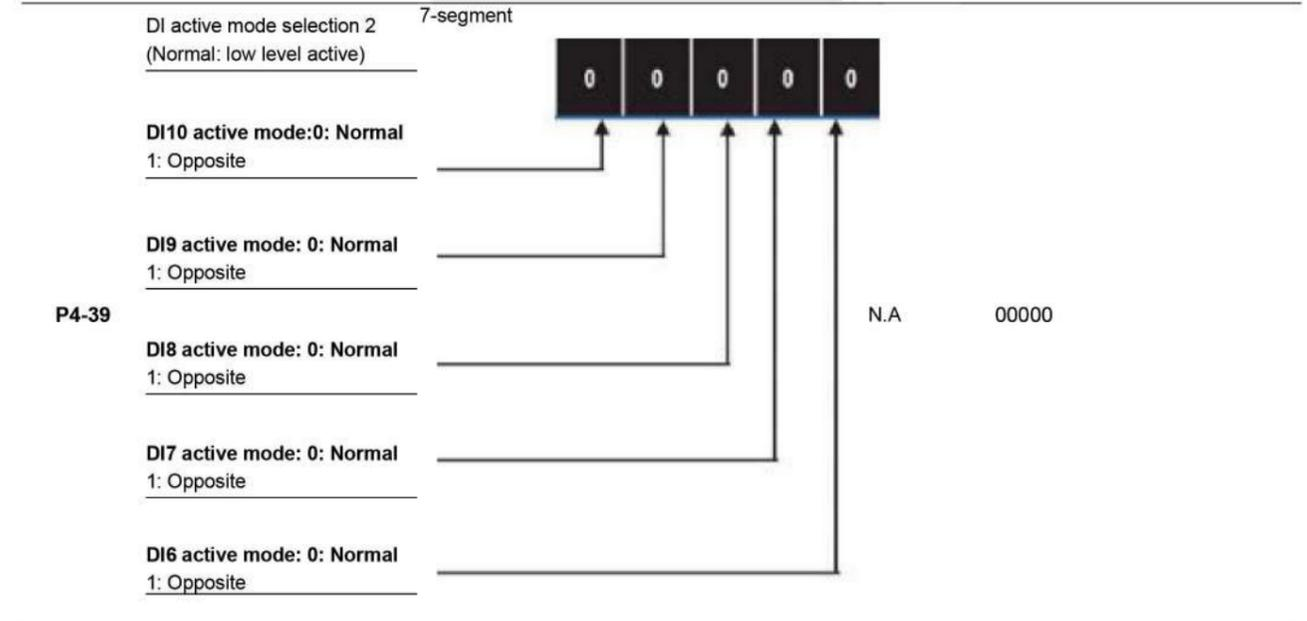
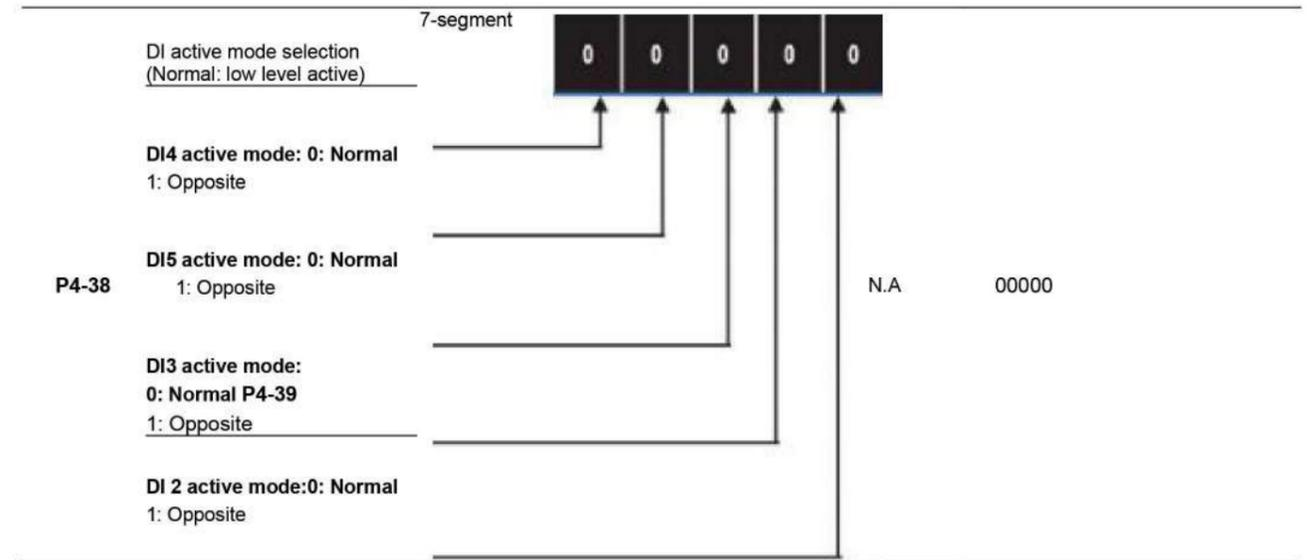

4.5 UPS Function

In all elevator applications, most time we will face the issue that passengers may be trapped in the car if power failure suddenly happens during use of the elevator. So the emergency evacuation mode is very important for safety. When the elevator is in UPS mode, the drive will be auto research light load direction to protect passengers can be reach levelling floor for safety.

CASE 1 UPS mode Light load search operation for output current of $\leq 100\%$

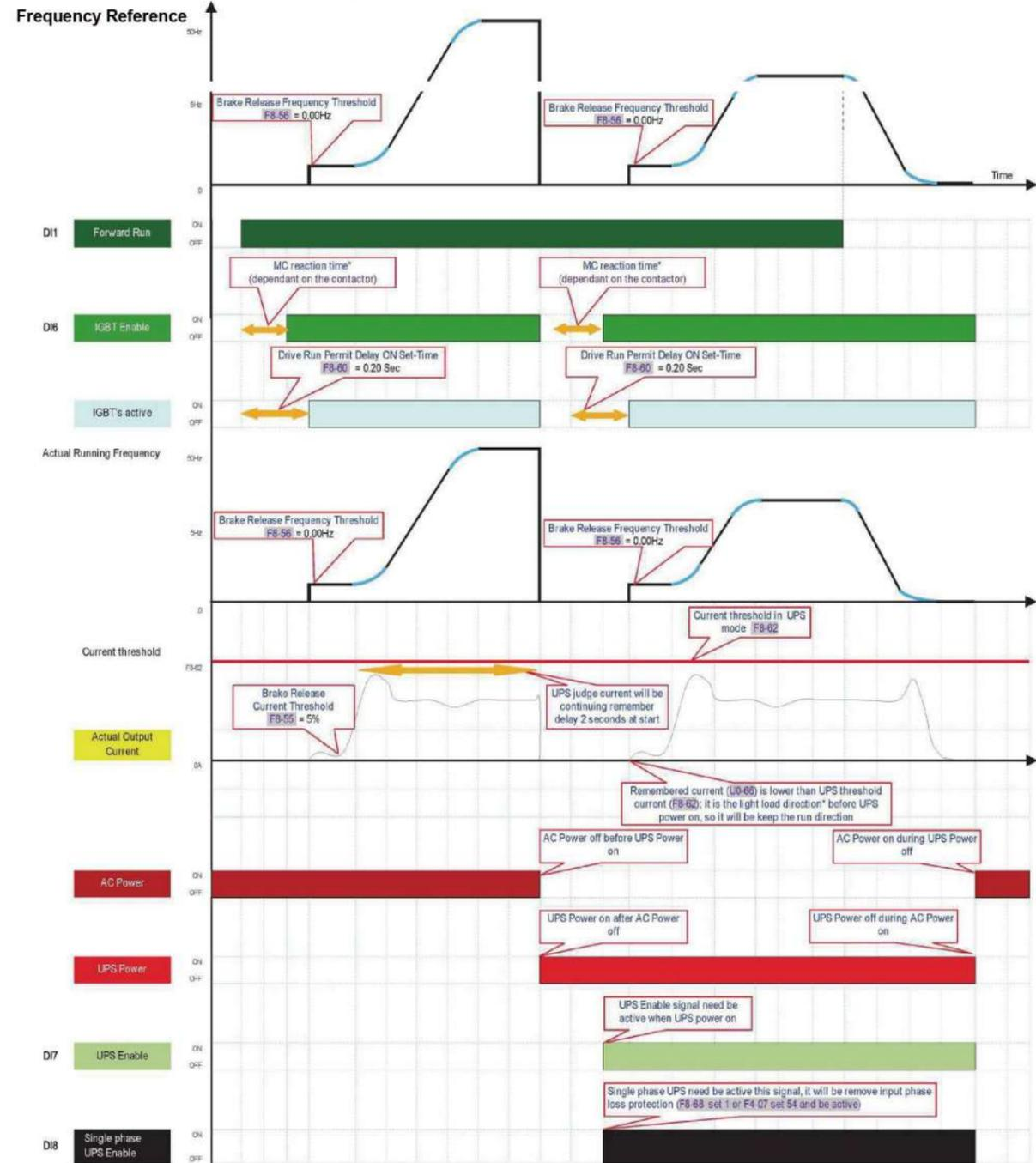

* Light load direction: UPS mode will be auto research light load direction, and it will be running to nearest light load direction floor. Which is decided by F8-62 and U0-66, if U0-66 is lower than F8-62, it will be continue to keep the run direction before UPS; otherwise it will be reverse the direction. For some applications, the status of Single phase UPS Enable needs to be checked before inverter starts up according to DI8 or F8-68, because it will be removed input phase loss protection in UPS mode, otherwise it will be trip Err12.

cAsE 2 UPS mode Light load search operation for output current of $> 100\%$

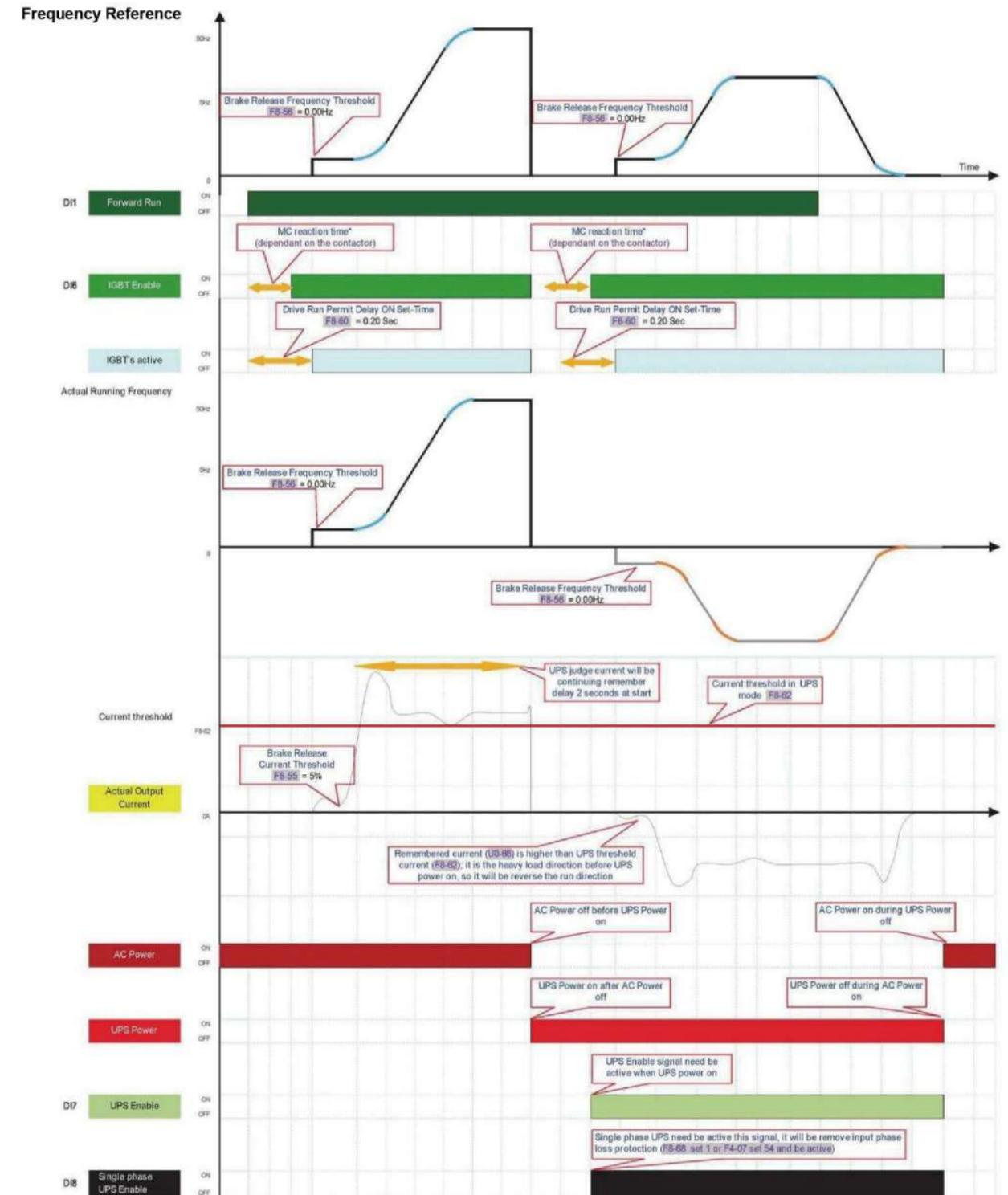

5 Function code table

NOTE: not all parameters are listed, here below are relevant to open loop elevator applications.

5.1 Group P0: fundamental

Function Code	Parameter name	Setting Range	Unit	Default	Commission I
P0-01	Motor 1 control mode	0: Sensor-less flux vector control (SFVC) 2: V/F control	N.A	2	
P0-02	Command source selection	0: Operation panel control (LED oFF) 1: Terminal control (LED on) 2: Communication control (LED flashing)	N.A	1	
P0-03	Main frequency source X selection	2: AI-1 3: AI-2 4: AI-3 6: Multi-reference	N.A	6	
P0-07	Frequency source selection	0: Main frequency source X	N.A	0	
P0-09	Rotation direction	0: Same direction 1: Reverse direction	N.A	0	
P0-10	Maximum frequency	50.00 to 100.00	Hz	50.00	
P0-15	Carrier frequency	0.5 to 11.0 (SVC mode: 0.5 to 9)	kHz	Model dependant	
P0-17	Acceleration time 1	0.00 to 650.00 0.0 to 6500.0 0 to 65000	(PO-19 = 2) (PO-19 = 1) (PO-19 = 0)	Sec	3.0
P0-18	Deceleration time 1	0.00 to 650.00 0.0 to 6500.0 0 to 65000	(PO-19 = 2) (PO-19 = 1) (PO-19 = 0)	Sec	2.0
P0-19	Acceleration/Deceleration time unit	0: 1 1: 0.1 2: 0.01	Sec	1	1

5.2 Group F1: motor 1 parameters

Function Code	Parameter name	Setting Range	Unit	Default	Commission
P1-00	Motor type selection	0: Common asynchronous motor 1: Variable frequency asynchronous motor	N.A	n	
P1-01	Motor rated power	0.1 to 1000.0	kW	Model dependent	
P1-02	Motor rated voltage	1 to 2000	V	400	
P1-03	Motor rated current	0.01 to 655.35 (For AC drive power < 55 kW) 0.1 to 6553.5 (For AC drive power > 55 kW)	A	Model dependent	
P1-04	Motor rated frequency	0.01 Hz to maximum frequency	Hz	50	
P1-05	Motor rated rotational speed	1 to 65535	RPM	1440	
P1-06	Stator resistance (asynchronous motor)	0.001 to 65.535 (AC drive power < 55 kW) 0.0001 to 6.5535 (AC drive power > 55 kW)	n	n	
P1-07	Rotor resistance (asynchronous motor)	0.001 to 65.535 (AC drive power < 55 kW) 0.0001 to 6.5535 (AC drive power > 55kW)	Q	0.000	
P1-08	Leakage inductive reactance (asynchronous motor)	0.01 to 655.35mH (AC drive power < 55 kW) 0.001 to 65.535 (AC drive power > 55 kW)	mH	0.00	
P1-09	Mutual inductive reactance (asynchronous motor)	0.01 to 655.35 (AC drive power < 55 kW) 0.001 to 65.535 (AC drive power > 55 kW)	mH	0.00	
P1-10	No-load current (asynchronous motor)	0.01 to P1-03 (AC drive power < 55 kW) 0.1 to P1-03 (AC drive power > 55 kW)	A	0.00	
P1-37	Auto tuning selection	0: No auto-tuning 2: Asynchronous motor dynamic auto-tuning 3: Asynchronous motor static auto-tuning(NEW)	N.A	0	

5.3 Group F2: vector control

Function Code	Parameter name	Setting Range	Unit	Default	Commission
P2-00	Speed loop proportional gain 1	Oto 100	N.A	10	
P2-01	Speed loop integral time 1	0.01 to 10.00	Sec	0.50	
P2-02	Switchover frequency 1	0.00 to P2-05	Hz	3.00	
P2-03	Speed loop proportional gain 2	Oto 100	N.A	30	
P2-04	Speed loop integral time 2	0.01 to 10.00	Sec	0.5	
P2-05	Switchover frequency 2	P2-02 to maximum output frequency	Hz	7.00	
P2-06	SVC slip gain	50 to 200	%	100	
P2-10	Torque upper limit (for SVC)	0.0 to 200.0 (% AC drive rated current)	%	150.0	
P2-13	Excitation adjustment proportional gain	Oto 20000	N.A	2000	
P2-14	Excitation adjustment integral gain	Oto 20000	N.A	1300	
P2-15	Torque adjustment proportional gain	Oto 20000	N.A	2000	
P2-16	Torque adjustment integral gain	Oto 20000	N.A	1300	

5.4 Group F3: VF control

Function code	Parameter Name	Setting Range	Unit	Default	Commission
P3-00	V/F curve setting	0: Linear V/F 1: Multi-point V/F 2 to 11: not relevant settings	N.A.	0	
P3-01	Torque boost	0.0 to 30.0 (if itisO, then auto torque boost is activated)	%	0	
P3-02	Cut-oFF frequency of torque boost	0.00 to max output frequency	Hz	50.00	
P3-03	Multi-point V/F frequency 1 (P1)	0.00 to P3-05	Hz	1.50	
P3-04	Multi-point V/F voltage 1 (V1)	0.0 to 100.0	%	6.0	
P3-05	Multi-point V/F frequency 2 (P2)	P3-03 to P3-07	Hz	3.00	
P3-06	Multi-point V/F voltage 2 (V2)	0.0 to 100.0	%	8.0	
P3-07	Multi-point V/F frequency 3 (P3)	P3-05 to rated motor frequency (P1-04)	Hz	8.00	
P3-08	Multi-point V/F voltage 3 (V3)	0.0 to 100.0	%	20.0	
P3-09	V/F slip compensation gain	Oto 200.0	%	0.0	
P3-10	V/F over-excitation gain	Oto 200	%	0	
P3-11	V/F oscillation suppression gain	OtoWO	%	30	
P3-13	Voltage source for V/F separation	Oto 8	N.A.	0	
P3-14	Voltage digital setting for V/F separation	0 to rated motor voltage	V	0	
P3-15	Voltage rise time of V/F separation	0.0 to 1000.0	s	0.0	
P3-18	Overcurrent stall prevention current limit (for VF mode)	100 to 200 (% AC drive rated current)	%	170	
P3-19	Overcurrent stall prevention enable(for VF mode)	0: Disable; 1: Enable	NA	1	
P3-20	Overcurrent stall prevention gain(for VF mode)	OtoWO	NA	20	
P3-22	Overvoltage stall prevention voltage limit(for VF/SVC)	650 to 800	V	770	
P3-23	Overvoltage stall prevention enable(for VF/SVC)	0: Disable; 1: Enable	N.A	0	
P3-24	Overvoltage stall prevention frequency gain(for VF/SVC)	OtoWO	N.A	30	
P3-25	Overvoltage stall prevention voltage gainfor VF/SVC)	OtoWO	N.A	30	

5.5 Group F4: input terminals

Function Code	Parameter name	Setting Range	Unit	Default	Commission i
P4-00	D11 function selection (Standard on-board)	0: No function 1: Forward RUN (FWD) 2 : Reverse RUN (REV) 3:Three-line Control 4: Jog Forward (FJOG)	N.A	1	
P4-01	DI 2 function selection (Standard on-board)	5: Jog Reverse (RJOG) 6: Terminal UP 7: Terminal DOWN 8: IGBT Enable	N.A	2	
P4-02	DI 3 function selection (Standard on-board)	9: Fault reset (RESET) 10: RUN Pause 11: Normally open (NO) input of external fault 12: Multi-reference terminal 1 13:Multi-reference terminal 2 14: Multi-reference terminal 3	N.A	12	
P4-03	DI 4 function selection (Standard on-board)	15: Multi-reference terminal 4 16:Terminal 1 for acceleration/deceleration time selection 17:Terminal 2 for acceleration/deceleration time selection	N.A	13	
P4-04	DI 5 function selection (Standard on-board)	18: Frequency source switchover 19: UP and DOWN setting clear (terminal, operation panel) 20: Command source switchover terminal 1	N.A	14	8
P4-05	DI 6 function selection (On-board expansion card)	21: Acceleration/Deceleration prohibited 22: PID pause 23: PLC status reset 24: Swing pause 25: Counter input	N.A	0	15
P4-06	DI 7 function selection (On-board expansion card)	26: Counter reset 27: Length count input 28: Length reset 29: Torque control prohibited	N.A	0	
P4-07	DI 8 function selection (On-board expansion card)	30: Pulse input (enabled only for DI5) 31: Reserved 32: Immediate DC braking 33: Normally closed (NC) input of external fault	N.A	0	
P4-08	DI 9 function selection (On-board expansion card)	34: Frequency modification forbidden 35: Reverse PID action direction 36: External STOP terminal 1 37: Command source switchover terminal 2 38: PID integral pause	N.A	0	
P4-09	D110 function selection (On-board expansion card)	39: Switchover between main frequency source X and preset frequency 40: Switchover between auxiliary frequency source Y and preset frequency 41: Motor selection terminal 1 42: Motor selection terminal 2 43: PID parameter switchover	N.A	0	

Function Code	Parameter name	Setting Range	Unit	Default	Commission
		44: User defined fault 1 45: User defined fault 2 46: Speed control/Torque control switchover 47: Emergency stop 48: External STOP terminal 2 49: Deceleration DC braking 50: Clear the current running time 51: Switchover between two-line mode and three line mode 52 to 59: Reserved			
P4-10	DI filter time	0.000 to 1.000	Sec	0.010	
P4-11	Terminal command mode	0 : Two-line mode 1 1: Two-line mode 2 2 : Three-line mode 1 3 : Three-line mode 2	N.A	0	
P4-12	Terminal UP/DOWN rate	0.01 to 65.535	Hz/s	1.00	
P4-13	AI curve 1 minimum input	0.00toP4-15	V	0.00	
P4-14	Corresponding setting of AI curve 1 minimum input	-100.00 to 100.00	%	0.0	
P4-15	AI curve 1 maximum input	P4-13 to 10.00V	Volt	5.00	
P4-16	Corresponding setting of AI curve 1 maximum input	-100.00 to 100.00	%	100.0	
P4-17	AI 1 filter time	0.00 to 10.00	Sec	0.10	
P4-38	DI valid mode selection (for D11 to DI5)	00000to 11111 (binary)	N.A	00000	
P4-39	DI valid mode selection 2 (forDI6toDI10)	00000to 11111 (binary)	N.A	00000	

5.6 Group F5: output terminals

Function Code	Parameter name	Setting Range	Unit	Default	Commission
P5-01	TA1-TB1-TC1 MC or Brake output.	0 : No output 1 : AC Drive running 2 : Fault output (stop) 3 : Frequency-level detection FDT1 output 4 : Frequency reached 5: Zero-speed running (no output at stop) 6 : Motor overload pre-warning 7 : AC Drive overload pre-warning 8 : Set count value reached 9: Designated count value reached 10 : Length reached 11: PLC cycle complete 12: Accumulated running time reached 13: Frequency limited 14: Torque limited 15: Ready for RUN 16 : AI-1 larger than AI-2 17 : Frequency upper limit reached 18 : Frequency lower limit reached (no output at stop) 19: Under-voltage state output 20 : Communication setting 21-22 : Reserved 23 : Zero-speed running 2 (having output at stop) 24 : Cumulative power-on time reached	N.A	2	
P5-02	TA2-TC2	25: Frequency-level detection FDT2 output 26: Frequency 1 reached 27: Frequency 2 reached 28: Current 1 reached 29: Current 2 reached 30: Timing reached 31: AI-1 input limit exceeded 32: Load becoming 0 33: Reverse running 34: Zero current state 35: Module temperature reached 36: Software current limit exceeded 37: Frequency lower limit reached (having output at stop) 38: Alarm output 39: Motor overheat warning 40: Current running time reached 41: Fault output (There is no output if it is the coast-to-stop fault and under-voltage occurs) 42: Brake output 43: MC (Magnetic contactor) output	N.A	43	
P5-03	TA3-TC3	38: Alarm output 39: Motor overheat warning 40: Current running time reached 41: Fault output (There is no output if it is the coast-to-stop fault and under-voltage occurs) 42: Brake output 43: MC (Magnetic contactor) output	N.A	42	
P5-03	7A4-TC4	38: Alarm output 39: Motor overheat warning 40: Current running time reached 41: Fault output (There is no output if it is the coast-to-stop fault and under-voltage occurs) 42: Brake output 43: MC (Magnetic contactor) output	N.A	0	
P5-07	AO1 function selection	0: Running frequency 1: Set frequency 2: Output current 3: Output torque (absolute value)	N.A	3	

5.7 Group F6: start and stop control

Function Code	Parameter name	Setting Range	Unit	Default	Commission
P6-00	Start mode	0 : Direct start 1: Rotational speed tracking restart 2: Pre-excited start (asynchronous motor)	N.A	0	
P6-03	Startup frequency	0.0 to 10.0	Hz	1.0	
P6-04	Startup frequency active set time	0.0 to 100.0	Sec	0.3	
P6-05	DC injection 1 level	0 to 150	%	0	
P6-06	DC injection 1 active set time	0.0 to 5.0	Sec	0	
P6-07	Acceleration/Deceleration mode	0: Linear acceleration/ deceleration 3: S-curve acceleration/ deceleration C	N.A	3	
P6-08	Time proportion of S-curve at Accel start	0.0% to Min[(100.0% - P6-U9), 80%]	%	80.0	
P6-09	Time proportion of S-curve at Accel end	0.0% to Min[(100.0% - P6-08), 80%]	%	10.0	
P6-10	Stop mode	0 : Decelerate to stop 1: Coast to stop	N.A	0	
P6-11	DC injection 2 frequency threshold	0.00 Hz to maximum frequency	Hz	0.50	
P6-12	DC Injection 2 delay ON set time	0.0 to 36.0	Sec	0.0	
P6-13	DC injection 2 level	0 to 150	%	30	
P6-14	DC injection 2 active set time	0.0 to 5.0	Sec	0.5	
P6-26	Time proportion of S-curve at Decel start	0.0% to Min[(100.0% - P6-27), 80%]	%	20.0	
P6-27	Time proportion of S-curve at Decel end	0.0% to Min[(100.0% - P6-26), 80%]	%	30.0	

5.8 Group F8: auxiliary functions

Function Code	Parameter Name	Setting Range	Unit	Default	Commission
P8-04	Deceleration time 2	0.0 to 6500.0	SEC	2.0	
P8-26	Frequency switchover point between deceleration time 1 and deceleration time 2	0.00 to maximum frequency	HZ	0.00	
P8-55	Brake release current threshold	0 to 200	%	5	
P8-56	Brake release frequency threshold	0.00 to 25.00	HZ	0	
P8-57	Brake release delay ON set time	0.0 to 5.0	sec	0.0	
P8-58	Brake apply frequency threshold	0.00 to 25.00	Hz	0.50	
P8-59	Brake apply delay OFF set time		Sec	0.2	
P8-60	Drive run delay ON set time	0.20 to 10.00	Sec	0.20	
P8-61	MC contactor delay OFF set time	0.00 to 10.00	Sec	0.20	

5.9 Group F9: fault and protection

Function Code	Parameter Name	Setting Range	Unit	Default	Commission
P9-00	Motor thermal protection enable selection	0: disable motor thermal protection; 1: enable motor thermal protection	N.A	1	
P9-01	Motor thermal protection coefficient	0.1 to w.u.o	N.A	1.00	
P9-02	Motor thermal protection prewarning coefficient	50 to 99	%	80	
P9-07	Ground fault detection Enable	0: Disable; 1: Enable detection ^[1] on power on; 2: Enable detection upon power on and upon start;	N.A	2	
P9-08	Braking operation voltage level	700 to 800	V	750	
P9-09	Fault auto reset times	0 to 20	N.A	0	
P9-11	Time interval of fault auto reset	0.1 to W.O.O	Sec	1.0	
P9-13	Drive output phase loss detection Enable	0: Disable; 1: Enable detection during running; 2: Enable detection upon start and during running	N.A	2	
P9-14	1st fault type	0 to 51	N.A.	N.A.	
P9-15	2nd fault type	0 to 51	N.A.	N.A.	
P9-16	3rd (latest) fault type	0 to 51	N.A.	N.A.	
P9-17	Frequency upon 3rd fault	N.A.	Hz	N.A.	
P9-18	Current upon 3rd fault	N.A.	A	N.A.	
P9-19	Bus voltage upon 3rd fault	N.A.	V	N.A.	
P9-20	Input terminal status upon 3rd fault	N.A.	N.A.	N.A.	
P9-21	Output terminal status upon 3rd fault	N.A.	N.A.	N.A.	
P9-22	AC drive status upon 3rd fault	N.A.	N.A.	N.A.	
P9-23	Power-on time upon 3rd fault	N.A.	N.A.	N.A.	

5.10 Group FC: multi-reference

Function Code	Parameter name	Setting Range	Unit	Default	Commission
PC-00	Reference 0	0.0 to 100.0	%	10.0%	
PC-01	Reference 1	0.0 to 100.0	%	100.0%	
PC-02	Reference 2	0.0 to 100.0	%	11.0%	
PC-03	Reference 3	0.0 to 100.0	%	12.0%	
PC-04	Reference 4	0.0 to 100.0	%	40.0%	
PC-05	Reference 5	0.0 to 100.0	%	13.0%	
PC-06	Reference 6	0.0 to 100.0	%	14.0%	
PC-07	Reference 7	0.0 to 100.0	%	15.0%	
PC-08	Reference 8	0.0 to 100.0	%	20.0%	

Attention!

P4-02 to P4-04 and P4-06 Multi-Reference

Preset Reference Selector		P4-02	P4-03	P4-04	P4-06
PC-00 : Reference 0	0	OFF	OFF	OFF	OFF
PC-01 : Reference 1	1	ON	OFF	OFF	OFF
PC-02 : Reference 2	2	OFF	ON	OFF	OFF
PC-03 : Reference 3	3	ON	ON	OFF	OFF
PC-04 : Reference 4	4	OFF	OFF	ON	OFF
PC-05 : Reference 5	5	ON	OFF	ON	OFF
PC-06 : Reference 6	6	OFF	ON	ON	OFF
PC-07 : Reference 7	7	ON	ON	ON	OFF
PC-08 : Reference 8	8	OFF	OFF	OFF	ON

5.11 Group FF: drive parameters

Function Code	Parameter name	Setting Range	Unit	Default	Commission
PF-00	Factory password	0 to 65535	NA	0	
PF-01	Drive code	1to 537	N.A.	Model dependent	
PF-02	G/P type selection	1: Gtype; 2: P type	N.A.	1	
PF-03	Drive rated power	0 to 6553.5	NA	Model dependent	display

5.12 Group FP: function code management

Function Code	Parameter name	Setting Range	Unit	Default	Commission
PP-00	User password	Oto 65535	N.A.	0	
PP-01	Parameter initialization	0: No operation 01: Restore factory settings except motor parameters 02: Clear records 04: Restore user backup parameters 501: Back up current user parameters	N.A.	0	
PP-03	Parameter display selection	7-segment 	N.A.	0	

Modified parameters:
0: No display
1: Display

Customized parameters:
0: No display
1: Display

5.14 Group A5: control optimization

Function Code	Parameter name	Setting Range	Unit	Default	Commission
B5-06	Under voltage threshold	60.0 to 140.0	%	60.0	100% is 350V
B5-09	Overvoltage tripping level	200.0 to 2500.0	V	810	

5.15 Group U0: monitoring

Function Code	Parameter name	Setting Range	Unit	Default	Commission
D0-00	Running frequency	N.A.	Hz	N.A.	
D0-01	Set frequency	N.A.	Hz	N.A.	
D0-02	Bus voltage	N.A.	V	N.A.	
D0-03	Output voltage	N.A.	V	N.A.	
D0-04	Output current	N.A.	A	N.A.	
D0-05	Output power	N.A.	kW	N.A.	
D0-06	Output torque	N.A.	%	N.A.	
D0-07	DI state	N.A.	N.A.	N.A.	
D0-08	DO state	N.A.	N.A.	N.A.	
D0-09	AH voltage	N.A.	V	N.A.	
D0-10	AI2 voltage	N.A.	V	N.A.	
D0-11	AI3 voltage	N.A.	V	N.A.	
D0-41	DI state visual display	N.A.	N.A.	N.A.	
D0-42	DO state visual display	N.A.	N.A.	N.A.	
D0-65	Torque upper limit	N.A.	%	N.A.	

6 Trouble shooting

6.1 Fault codes

Display	Fault Name	Possible Causes	Solutions												
Err02	Overcurrent during acceleration	<ol style="list-style-type: none"> The output circuit is short circuited. The acceleration time is too short. Manual torque boost or V/F curve is not appropriate. The power supply is too low. The startup operation is performed on the rotating motor. A sudden load is added during acceleration. The AC drive model is of too small power class. 	<ol style="list-style-type: none"> Eliminate short circuit. Increase the acceleration time PO-17. Adjust the manual torque boost or V/F curve. Check that the power supply is normal. Select speed tracking restart or start the motor after it stops. Remove the added load. Select a drive of higher power class. 												
Err03	Overcurrent during deceleration	<ol style="list-style-type: none"> The output circuit is short circuited. The deceleration time is too short. The power supply is too low. A sudden load is added during deceleration. The braking resistor is not installed. 	<ol style="list-style-type: none"> Eliminate short circuit. Increase the deceleration time PO-18. Check the power supply, and ensure it is normal. Remove the added load. Install the braking resistor. 												
Err04	Overcurrent at constant speed	<ol style="list-style-type: none"> The output circuit is short circuited. The power supply is too low. A sudden load is added during operation. The AC drive model is of too small power class. 	<ol style="list-style-type: none"> Eliminate short circuit. Adjust power supply to normal range. Remove the added load. Select a drive of higher power class. 												
Err05	Overvoltage during acceleration	<ol style="list-style-type: none"> The DC bus voltage is too high[^]. An external force drives the motor during acceleration. The acceleration time is too short. The braking resistor is not installed. 	<ol style="list-style-type: none"> Replace with a proper braking resistor. Cancel the external force or install braking resistor. Increase the acceleration time. Install a braking resistor. 												
Err06	Overvoltage during deceleration	<ol style="list-style-type: none"> The DC bus voltage is too high[^]. An external force drives the motor during deceleration. The deceleration time is too short. The braking resistor is not installed. 	<ol style="list-style-type: none"> Replace with a proper braking resistor. Cancel the external force or install braking resistor. Increase the deceleration time. Install the braking resistor. 												
Err07	Overvoltage at constant speed	<ol style="list-style-type: none"> The DC bus voltage is too high[^]. An external force drives the motor during deceleration. 	<ol style="list-style-type: none"> Replace with a proper braking resistor. 2: Cancel the external force. 												
☆: Voltage thresholds															
<table border="1"> <thead> <tr> <th>Voltage Class</th> <th>DC Bus Overvoltage threshold</th> <th>DC Bus Undervoltage threshold</th> <th>Braking operation level</th> </tr> </thead> <tbody> <tr> <td>Three-phase 220 V</td> <td>400VDC</td> <td>200VDC</td> <td>380VDC</td> </tr> <tr> <td>Three-phase 380 V</td> <td>810VDC</td> <td>350VDC</td> <td>750VDC</td> </tr> </tbody> </table>				Voltage Class	DC Bus Overvoltage threshold	DC Bus Undervoltage threshold	Braking operation level	Three-phase 220 V	400VDC	200VDC	380VDC	Three-phase 380 V	810VDC	350VDC	750VDC
Voltage Class	DC Bus Overvoltage threshold	DC Bus Undervoltage threshold	Braking operation level												
Three-phase 220 V	400VDC	200VDC	380VDC												
Three-phase 380 V	810VDC	350VDC	750VDC												
Err08	Control power fault	The input voltage exceeds the allowed range.	Adjust the input voltage to within the allowed range.												

Display	Fault Name	Possible Causes	Solutions
Err09	Undervoltage	<ol style="list-style-type: none"> Instantaneous power failure occurs. The input voltage exceeds the allowed range The DC bus voltage is too low# The rectifier bridge and buFFer resistor are faulty. The drive board is faulty. The control board is faulty. 	<ol style="list-style-type: none"> Reset the fault. Adjust the input voltage to within the allowed range. 3 to 6: Seek for maintenance.
Err10	Drive overload	<ol style="list-style-type: none"> The load is too heavy or the rotor is locked. The drive is of too small power class. 	<ol style="list-style-type: none"> Reduce the load, or check the motor, or check the machine whether it is locking the rotor. Select a drive of higher power class.
Err11	Motor overload	<ol style="list-style-type: none"> P9-01 is too small. The load is too heavy or the rotor is locked. The drive is of too small power class. 	<ol style="list-style-type: none"> Set P9-01 correctly. Reduce load, or check motor, or check the machine whether it is locking the rotor. Select a drive of larger power class.
Err12	Power input phase loss	<ol style="list-style-type: none"> The three-phase power supply is abnormal. The drive board is faulty. The lightning protection board is faulty. The control board is faulty. 	<ol style="list-style-type: none"> Check the power supply. 2 to 4: Seek for maintenance.
Err13	One drive output phase loss	<ol style="list-style-type: none"> The cable between drive and motor is faulty. The drive's three-phase output is unbalanced when the motor is running. The drive board is faulty The IGBT is faulty. 	<ol style="list-style-type: none"> Check the cable. Check the motor windings. 3 to 4: Seek for maintenance.
Err14	IGBT overheat	<ol style="list-style-type: none"> The ambient temperature is too high. The air filter is blocked. The cooling fan is damaged. The thermal sensor of IGBT is damaged. The IGBT is damaged. 	<ol style="list-style-type: none"> Reduce the ambient temperature. 2: Clean the air filter. 3 to 5: Seek for maintenance.
Err15	External equipment fault	<ol style="list-style-type: none"> External fault signal is input via DI. External fault signal is input via VDI. 	Reset the fault
Err16	Communication fault	<ol style="list-style-type: none"> The host computer is abnormal. The communication cable is faulty. The extension card type set in PO-28 is incorrect. The communication parameters in group FD are set improperly. 	<ol style="list-style-type: none"> Check cabling of the host computer. Check the communication cabling. Set PO-28 correctly. Set the communication parameters properly.
Err18	Current detection fault	The drive board is faulty.	Replace the drive board.
Err19	Motor tuning fault	<ol style="list-style-type: none"> Motor parameters are wrong. Motor tuning overtime. 	<ol style="list-style-type: none"> Check motor parameters P1-00 to P1-05. Check the wiring between drive and motor.
Err21	EEPROM readwrite fault	The EEPROM chip is damaged.	Replace the main control board.
Err23	Short circuit to ground	The motor is short-circuited to ground.	Replace the cables or motor.
Err26	Accumulative running time reached	The accumulative running time reaches the setting of P8-17.	Clear the record by performing parameter initialization (set PP-01 to 2).
Err27	User-defined fault 1	<ol style="list-style-type: none"> The user-defined fault 1 signal is input via DI. User-defined fault 1 signal is input via VDI. 	Reset the fault.

Display	Fault Name	Possible Causes	Solutions
Err28	User-defined fault 2	1. The user-defined fault 2 signal is input via DI 2. The user-defined fault 2 signal is input via VDI.	Reset the fault.
Err29	Accumulative power-on time reached	The accumulative power-on time reaches the setting of P8-16.	Clear the record by performing parameter initialization (set PP-01 to 2).
Err30	OFF load fault	OFFload when ifs running.	Check the connection between motor and load.
Err31	PID feedback lost during running	The PID feedback is lower than FA-26.	Check the PID feedback signal or set FA-26 to a proper value.
Err40	Quick current limit	1. The load is too heavy or the rotor is locked. 2. The drive is of too small power class.	1: Reduce the load, or check the motor, or check the machine whether it is locking the rotor. 2: Select a drive of higher power class.
Err41	Motor switchover fault during running	The current motor is switched over via a terminal during running of the AC drive.	Switch over the motor only after the AC drive stops.
Err61	Two or three drive output phases loss	1. The drive output connections get loose; 2. The output contactor gets wrongly operated or malfunctions.	1. Check drive output connections; 2. Check drive output contactor.

6.2 Common symptoms and diagnostics

Fault Name	Possible Causes	Solutions
There is no display at power-on.	1. There is no power supply or the power supply is too low. 2. The switching power supply on the drive board is faulty. 3. The rectifier bridge is damaged. 4. The buFFer resistor of the drive is damaged. 5. The control board or the keypad is faulty. 6. The cable between the control board and the drive board or keypad breaks.	1: Check the power supply. 2 to 5: Seek for maintenance. 6: Re-connect the 4-core and 28-core flat cables, or seek for maintenance.
"AAA" is displayed at power-on.	1. The cable between the drive board and the control board is in poor contact. 2. The control board is damaged. 3. The motor winding or the motor cable is short-circuited to the ground. 4. The power supply is too low.	1: Re-connect the 4-core and 28-core flat cables, or seek for maintenance. 2: Seek for maintenance. 3: Check the motor or replace it, and check the motor cable. 4. Check the power supply according to chapter 1.3.
The display is normal upon power-on, but "AAA" is displayed after start and the motor stops immediately.	1. The cooling fan is damaged or the rotor is locked. 2. A certain terminal is short-circuited.	1: Replace cooling fan, or check the machine whether it is locking the rotor. 2: Eliminate short circuit
Err14 is reported frequently.	1. The carrier frequency is set too high. 2. The cooling fan is damaged, or the air filter is blocked. 3. Components (thermal coupler or others) inside the drive are damaged.	1: Reduce PO-15. 2: Replace the fan and clean the air filter. 3: Seek for maintenance.
The motor does not rotate after the AC drive outputs a non-zero reference.	1. The motor or motor cable is damaged. 2. The motor parameters are set improperly. 3. The cable between the drive board and the control board is in poor contact. 4. The drive board is faulty. 5. The rotor is locked.	1: Check the motor, or check the cable between the drive and the motor. 2: Check and re-set motor parameters. 3: Re-connect the 4-core and 28-core flat cables, or seek for maintenance. 4: Seek for maintenance. 5: Check the machine whether it is locking the rotor.
The DI terminals are disabled.	1. The DI parameters are set incorrectly. 2. The input signal is incorrect. 3. The wire jumper between OP and +24V is in poor contact. 4. The control board is faulty.	1: Check and reset DI parameters in group P4. 2: Check the input signals, or check the input cable. 3: Check the jumper between OP and +24 V. 4: Seek for maintenance.
The drive reports overcurrent and overvoltage frequently.	1. The motor parameters are set improperly. 2. The acceleration/deceleration time is too small. 3. The load fluctuates.	1: Reset motor parameters. 2: Set proper acceleration/deceleration time. 3: Check the machine, or seek for maintenance.



Email id. Info@dezaw.com

Webmail www.dezaw.com